

DVS POWER PACK

WC00-155

The DVS Power Pack is designed to power most DVS products direct from its battery. An onboard Intelligent Charger keeps the battery at an optimum charge level. In the event of a power out, the battery will continue to supply power for up to 10 days depending on load.

PRODUCT NUMBER

WC00-155

TECHNICAL DATA

Control Box:

Weight	1.45 kg
Material	ABS Plastic
Power source	Mains Spur
IP rating	65
Amps	200 mA (MAX)
Voltage	6.9V DC

ADDITIONAL INFORMATION

For Installation & Set-Up see WC00-155 Instructions

Compatible With

DVS Battery Operated WC Flushvalve (Low Voltage Mains)

DVS Tap Control System

DVS No-Touch Taps

DVS Programmable Sensor

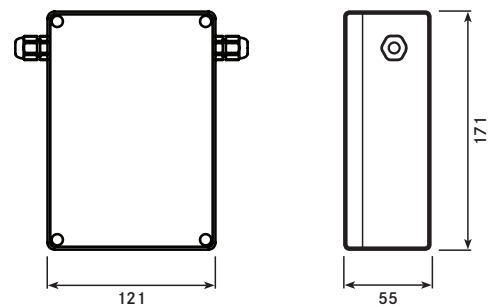

ALL DIMENSIONS IN MM

2017-11-16, Dart Valley Systems